



Jenny

Skill Level



Sizes

Small (Medium, Large) to fit 1 (2, 3) years

Finished Chest: 22 (25, 28)"

Materials



Yarn: 2 (2, 2) balls **Angel** (100% Acrylic; 284 yards/260 meters; 3½ ounces/100 grams per ball).

Knitting Needles: US 7 (4.5mm) straight and 16" circular or double-point needles **or size to obtain gauge.**

Extras: Stitch holder, stitch markers, yarn needle

Gauge

18 sts and 26 rows = 4" in pat st

Abbreviations:

Beg – beginning

Dec – decrease

Inc – increase

K – knit

K2tog – knit 2 sts together (decreases 1 st)

MI – pick up center bar between two stitches and place on left needle, knit this stitch, making sure stitch is twisted as you knit to avoid a hole (increases 1 st)

P – purl

P2tog – purl 2 sts together (decreases 1 st)

Pat st – pattern stitch

Rep – repeat

RS – right side

Ssk – slip next 2 stitches individually knitwise, slip them back to left needle in this position, knit them together through the back loops (decreases 1 st)

Ssp – slip next 2 sts individually knitwise, slip them back to left needle in this position, purl them together through the back loops (decreases 1 st)

St(s) – stitch(es)

WS – wrong side



Pattern Stitch

Row 1 (RS): * P3, k3; rep from * across row, ending with a k3 or p3 if necessary to finish row.

Row 2: Knit.

Rep Rows 1 and 2 for pattern.

Back

Cast on 48 (54, 60) sts. Work in Garter st (knit every row) for 8 rows (approximately 1"). Beg with Row 1 (RS), work in pat st until piece measures approximately 8 (8½, 9)" from beg. Place markers at each end of last row to mark underarms. Continue even in pat st until piece measures 13½ (14¼, 15)" from beg, ending with a WS row. Bind off 12 (14, 15) sts for shoulder at beg of next 2 rows, place center 24 (26, 30) sts on holder for back neck.

Front

Work same as Back, and, **at the same time** when piece measures 9 (9¼, 9½)" from beg, work Neck Shaping: Work 24 (27, 30) sts in pat st to center, attach second ball of yarn and complete row. Work both sides at the same time with separate balls of yarn. Dec 1 st at each neck edge every row 8 (8, 1) times, then every 2 rows 4 (5, 13) times, then every 0 (0, 4) rows 0 (0, 1) time – 12 (14, 17) sts remain each side. Continue even in pat st until piece measures same as Back from beg. Bind off.

Sleeve (make 2)

Cast on 24 (27, 27) sts. Work in Garter st (knit every row) for 8 rows (approximately 1"). Beg with Row 1 (RS), work in pat st and inc 1 st on each side every 2 rows 7 (4, 5) times, then every 4 rows 6 (9, 9) times, working additional sts into pat st – 50 (53, 55) sts. Continue even in pat st until piece measures 8 (8½, 9)" from beg. Bind off.

Garter St Neck Band

Sew shoulder seams. With RS facing, using circular needle or double-point needles and beg at shoulder seam, place back neck 26 (28, 30) sts on needle, pick up and knit 23 (25, 30) sts from left neck edge, place center marker, M1 st in center, pick up and knit 23 (25, 30) sts from right neck edge, place end of round marker – 73 (79, 91) sts.

Round 1: Knit to within 2 sts of center marker, ssk, slip marker, k1, k2tog, knit to end of round.

Round 2: Purl to within 2 sts of center marker, ssp, slip marker, k1, p2tog, purl to end of round.

Rep Rounds 1 and 2 until band measures approximately 1¼ (1½, 1½)". Bind off loosely.

Finishing

Sew top of sleeves between markers, sew side seams from wrist to waist; weave in ends.

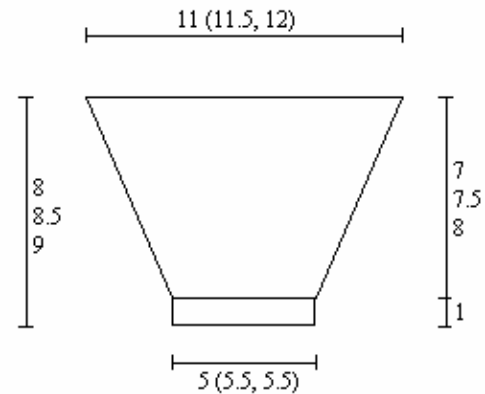
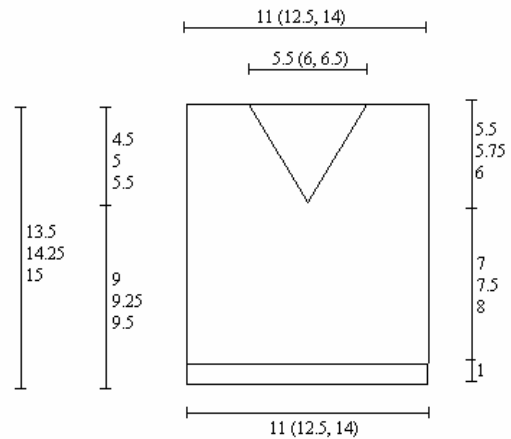

For more free patterns, visit www.premieryarns.com.

© 2009 Premier Yarns. All rights reserved.

This pattern may not be reproduced for business, trade or sale.



Yarnmarket.com, BargainYARNS.com, Yarnindex.com, ShearBagatelle.com and KnitchMagazine.com are subsidiaries of Yarnmarket, LLC.