



Trends© knitted in Elite
by Universal Yarn, Inc.

P0007



Abbreviations:

K – knit
P – purl
St(s) – stitch(es)
St st – stockinette stitch
Dec – decrease by knitting 2 st together



Easy

Size: Small (Medium, Large, X-Large) to fit bust measurements: 32, (36, 40, 44)''

Materials:

10 (12, 13, 16) skeins Elite 93% Acrylic 7% Glitter,
71 yds/65 m per 50 g.

US Size 10/5.5 mm needles *or needle needed to
obtain gauge*
4 buttons

Gauge: 15 sts and 21 rows per 4''/10 cm over st st

Back:

Establish rib pat on Row 1: *K2, P2. Repeat from *.
End K2. Work 15 rows. (2.75'')
Row 16 Start st st work for 12.5 (13, 14, 14.5)''
[row 50, 52, 58, 60].

Armhole Shaping

Bind off 3 (4, 5, 7) sts at beg of next 2 rows.
Dec 1 st each side, every other row 2 (4, 5, 6) times.
Cont in st st until piece measures 17 (18.5, 20, 21) ''
from start, Establish K2, P2 rib pattern at shoulder.
Work 8 (9, 10, 11) rows.

Shape Shoulders and Back Neck

Continue in pat st, bind off 4 (4, 5, 5) sts beg of
next row. At beg of next row, bind off 4 (4, 5, 5)
sts, work 8 (8, 10, 10) sts, attach a second ball of
yarn and bind off 24 (26, 27, 28) back neck
sts. Complete row. At beg of next row, bind off 4
(4, 5, 5) sts and dec 1 st at each neck edge. Bind off
4 (4, 5, 5) sts beg of next row. Bind off 4 (4, 4, 5)
sts beg of next 2 rows.

Front:

Make two, [reverse shaping]
Cast on 29 (34, 38, 42) sts. Establish rib pat on Row
1: *K2, P2. Repeat from *. End K2.
Work 15 rows [2.75''].
Work as for back, including all shaping, and, at the
same time when piece measures 16 (17, 18.5, 19) ''
[row 68, 74, 82, 84]

Begin Neck Shaping

At neck edge, bind off 6 (5, 4, 5) sts, then 0 (2, 2, 2)
sts at neck edge 2 times.

Knit, Relax, Smile, Repeat!

Then at neck edge, dec 1 (1, 2, 1) sts 7 (5, 6, 6) times.

Cont in pat st until piece measures 17 (20.5, 22, 23)" from start. Establish same K2, P2 rib pattern as back. Work 8 rows.

Beg – beginning

Sleeves:

Cast on 30 (34, 36, 40) sts.

Work same as body rib for 15 rows [2.75"].

Begin sleeve shaping for size:

Small: Inc 1 st on each side every 6 rows 4 times, then every 6 rows 8 times.

Medium: Inc 1 st on each side every 4 rows 7 times, then every 6 rows 8 times.

Large: Inc 1 st on each side every 6 rows 9 times, then every 8 rows 4 times.

X-Large: Inc 1 st on each side every 8 rows 13 times. Cont in st st until piece measures 16 (18, 20, 20.5)".

Work shoulder shaping (at shoulder edge) to correspond with back.

Cap Shaping:

Bind off 3 (4, 5, 7) sts each side.

Dec 1 st each side, every other row, 2 (4, 5, 6) times

Dec 1 st each side every row 10 (11, 11, 11) times.

Dec 1 st each side every 2nd row 2 (4, 4, 4) times.

Bind off 2 sts at the beg of next 4 rows.

Bind off rem 8 (18, 12, 10) sts.

Join seams.

Weave in all ends. Seam each shoulder. 12, (12, 14, 15) sts.

Lightly block all pieces.

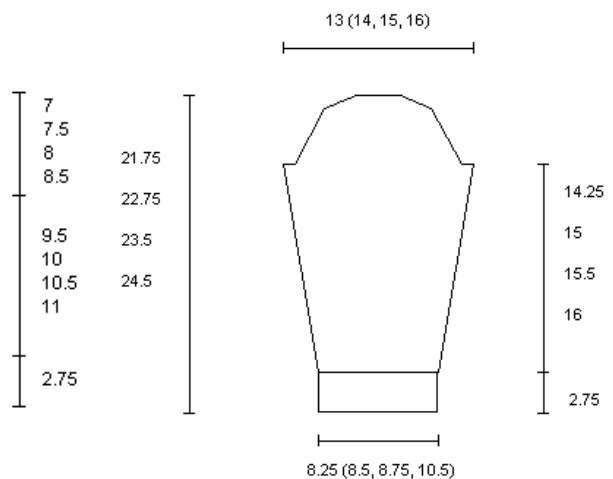
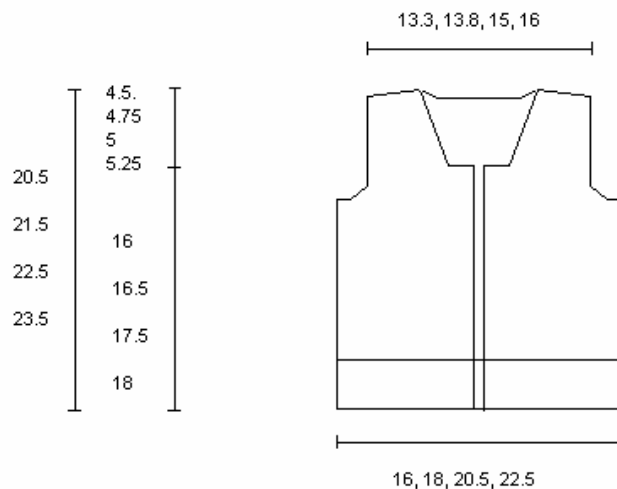

Finishing:

Neck Band: RS facing, pick up 6 (5, 4, 5) bound off sts from right front, pick up (4, 4, 4) sts from side bind off, pick up 25 (19, 19, 21) side neck sts, pick up 32 (34, 35, 36) back neck sts, pick up 25 (19, 19, 21) left side neck sts, pick up 0 (4, 4, 4) from side bind off, pick up 6 (5, 4, 5) bound off sts. Working back and forth, Establish K2, P2 pat. Inc or dec as necessary on the first row to balance pat. Work for 1 1/2". Bind off loosely in pat.

Right Front Band:

RS facing, pick up 74 (76, 82, 84) sts. Work 1" in 2x2 rib, end RS.

Bind off the bottom 7" in pattern, continue working top 9" of the band for another 5 rows in rib, bind off loosely in pattern.

Left Front Band:

RS facing, pick up 74 (76, 82, 84) sts. Work 1" in 2x2 rib, end WS.

Knit, Relax, Smile, Repeat!

Bind off the bottom 7 (7.5, 8, 8.5)" in pattern, continue 9 (9, 10, 10)" of the band, in rib, for another 2 rows, then:

For **Small** and **Medium** sizes work buttonhole row over 42 sts, as follows:

K2, Yo, P1, (K2, P2) 2 times,

K2, Yo, P1, (K2, P2) 2 times,

K2, Yo, P1, (K2, P2) 2 times,

K2, Yo, P1, K2.

For **Large** and **X-Large** over 48 sts, as follows:

K2, Yo, P1, (K2, P2) 3 times,

Yo, K1, (P2, K2) 3 times,

Yo, P1, (K2, P2) 3 times,

Yo, K1, P2.

Knit 2 more rows in 2x2 rib. Bind off loosely in pattern.

Finishing: Sew sleeves to body, seam from wrist to hem, sew buttons matching buttonholes. Weave in all ends.

Knit, Relax, Smile, Repeat!

www.universalyarn.com
Trends in Elite

All rights reserved.

This pattern may not be reproduced for business, trade or sale. 2006©

Yarnmarket.com, BargainYARNS.com, Yarnindex.com, ShearBagatelle.com
and KnitchMagazine.com are subsidiaries of Yarnmarket, LLC.